



**HOUSELINER**<sup>®</sup>  
SYSTEM

# RAPTOR CUTTER



**HOUSELINER**<sup>®</sup>

USER MANUAL / ANVÄNDARMANUAL

# HOUSELINER RAPTOR CUTTER

DRAIN CLEANING

**RAPTOR  
CUTTER**

## TABLE OF CONTENTS

### 1. GENERAL INFORMATION

- 1 Usage
- 1 EU Declaration of confirmation
- 1 Compliance in the United States of America
- 1 Risk assessment
  
- 1 CE-marking and labelling
- 1 Initialization and inspection

### 2. SAFETY INSTRUCTIONS

- 2 Injuries associated with connectors, pinching points, or moving parts
- 2 Leaving the machine unattended
- 2 Personal protective equipment

### 3. PRE-OPERATION INSTRUCTIONS

- 3 1 General condition
- 3 Reel and spindle
- 3 Tools installment

### 4. AFTER-OPERATION INSTRUCTIONS

- 4 Cleaning
- 4 Inspections

### 5. OPERATING THE MACHINE

- 5 Startup
- 5 Shutdown
- 5 Adjustment of torque strength
- 5 Adjustment of speed
- 5 Running the machine counterclockwise
- 5 Operating the machine with the foot pedal
- 5 Recommended torque and speed
- 5 Error codes and their meanings

### 6. MAINTENANCE

- 6 Cleaning
- 6 Lubrication
- 6 Electricity

### 7. INSPECTIONS

- 7 Routine inspection every 20 hours of runtime

### 8. REEL REPLACEMENT

As following

### 9. PARTS LIST

As following

### 10. ENVIRONMENTAL ASPECT

## Limitation of liability

All content in this document is obtained without warranties of any kind, neither expressed nor implied. Sacpro AB cannot be held liable for any direct, indirect, or incidental damages arising out of access to or use of this document. Sacpro AB neither assumes responsibility nor shall be held financially liable for any damages arising out of access to or use of this document.

### Copyright © 2023 Sacpro AB

The contents of this document may not be distributed, reproduced, copied, modified or forwarded without written permission from Sacpro AB. The material may not, under any circumstances, be used for commercial purposes. This applies to everything in this document, both text and images.

### Trademarks

Houseliner® are registered trademarks of Sacpro AB. Unless otherwise stated, all trademarks and materials in this document are protected by copyright and may not be used without the prior written consent of Sacpro.

## CONTACT

### Sacpro AB

Källviksv. 10  
S-791 52 Falun  
Sweden

+46 (0)23-79 06 50

info@sacpro.se

www.sacpro.se

## 1. GENERAL INFORMATION

This manual consists of instructions for installment, operation, recycling, and maintenance.

### 1.1 Usage

Raptor is designed and manufactured for use in pipes and liners only. It is designed for use with materials and equipment approved for safe application in sewer cleaning and as part of the pipe reinstatement process for pipes ranging from 40mm to 150mm in diameter (1/4 inch to 6 inches).

The machine must only be operated by individuals who have read the manual; the instructions within must be followed without questioning. Additionally, it is prohibited to operate the machine in rainy conditions, any damage or malfunction caused by such usage will not be covered by the warranty.

### 1.2 EU Declaration of confirmation

Raptor is approved via a declaration of confirmation document. The standard applied to fulfill the EU declaration of confirmation in Directive 2006/42/EC, and SFS-EN ISO 12100 for machine manufacturing.

### 1.3 Compliance in the United States of America

In the United States of America, there is no standardized national law requiring products to bear a specific marking for market entry. Products can be brought to market without a mandated USA compliance marking.

Each state within USA has its own set of liability laws and standards. Federal agencies are responsible for formulating safety requirements and conducting compliance inspections. The presence of a USA compliance marking is not a legal obligation, and even products deemed dangerous or defective may still be placed on the market, although manufacturers are obligated to report such instances.

### 1.4 Risk assessment

Risk assessment has been conducted on 2023-11-28. All risks associated with the use of the machine are genuine, and by following the safety instructions, the risk of an injury occurring can be kept low.

### 1.5 CE-marking and labeling

Raptor has been appropriately risk evaluated according to Directive 2006/42/EC. It is CE-marked. If your unit does not have a CE marking, please contact your reseller immediately to obtain a CE-approved unit.

### 1.6 Initialization and inspection

The electrical hardware of Raptor has been inspected according to SFS-EN-60204-1 before initialization.



## 2. SAFETY INSTRUCTIONS

Read and fully understand this manual before operating the machine. Using the machine without having read and comprehended the manual is strictly prohibited.

### 2.1 Injuries associated with connectors, pinching points, or moving parts

Exercise caution and be aware of a moderate risk of injury to hands or other body parts that may occur when caught between connectors, pinching points, or moving parts. It is essential to remain vigilant and take appropriate safety measures to prevent any potential harm or accidents in the vicinity of these areas.

### 2.2 Leaving the machine unattended

Always ensure that the machine is never left with power connected. If you need to step away from the machine, it is imperative to disconnect the power and take the remote with you for added safety and security.

### 2.3 Personal protective equipment

Individuals operating the machine must always wear appropriate protective equipment. Protective eyewear, and ear protection is mandatory for everyone within a 5-meter radius, including the operator.

Workwear must be suitable to prevent sleeves or any other part of clothing from getting caught between the rotating parts of the machine.

### WARNING

*Only a grounded connection may be used.*

*Improper use may result in electric shock or damage to the equipment.*



### 3. PRE-OPERATION INSTRUCTIONS

Before operating the machine, it is imperative to conduct a thorough inspection to ensure correct and safe operation. Thoroughly address the following:

#### 3.1 General condition

Carefully inspect the unit's overall condition. Examine cables for integrity and secure connections, check switches for functionality, assess wheels for wear and alignment, scrutinize the frame for damage, make sure the bearings turn freely, examine the shaft casing for integrity, check the reel for proper winding, and ensure the reel lock's reliability.

#### 3.2 Reel and spindle

Confirm proper securing of the shaft hub to the spindle, verify lubrication for smooth shaft operation, and check for the absence of epoxy resin on the reel to prevent potential damage to frame bearings and ensure optimal machine functionality.

#### 3.3 Tools installment

Confirm the application of the right torque strength based on the workload. Additionally, when attaching tools to the shaft, tighten firmly but not excessively to avoid damage to components such as cables or threads.

If any point does not comply, the machine must not be used until the issue is resolved.

### 4. AFTER-OPERATION INSTRUCTIONS

After using the machine, make sure to clean it thoroughly to maintain good condition and prevent future malfunctions. Perform a detailed inspection as described later for a comprehensive check.

#### 4.1 Cleaning

After using the machine, make sure to wipe the outer casing thoroughly, ensuring no epoxy residue remains. Use a damp cloth and cleanser for this purpose.

**DO NOT USE ANY KIND OF SOLVENT SUCH AS THINNER, ACETONE, OR OTHER BASED SUBSTANCES. DAMAGE TO THE PAINT SURFACE MAY OCCUR.**

#### 4.2 Inspections

Please follow the instructions provided in the previous chapter, 'PRE-OPERATION INSTRUCTIONS, 3'.



# SHAFT SIZES

\*Not to scale

## 5. OPERATING THE MACHINE

The operator is responsible for the correct torque and speed settings. Severe damage may occur if torque limits have not been pre-studied.

**Sacpro AB (SE556341-1288) will not stand responsible for any damage caused by the operator.**

### 5.1 Startup

Connect the machine to the power grid and deactivate the emergency stop on the wireless remote. Press the torque - and + buttons until you hear a beeping sound.

### 5.2 Shutdown

Stop the rotation by pressing the button corresponding to the direction of the machine's rotation. After the machine has completely stopped spinning, activate the emergency stop button on the remote, and then disconnect the machine from the power grid.

### 5.3 Adjustment of torque strength

To adjust the torque strength, use the 'Torque +' button to increase or the 'Torque -' button to decrease; the remote screen will display the selected torque strength accordingly.

### 5.4 Adjustment of speed

To adjust the speed, press the 'Speed +' button to increase or the 'Speed -' button to decrease; the remote's screen will display the selected speed accordingly. The minimum speed is set at 10%, equivalent to 330 RPM, while the maximum speed is capped at 120%, corresponding to 2350 RPM.

### 5.5 Running the machine counterclockwise

To change the machine's direction to counterclockwise, press and hold the 'CCW' button for 5 seconds. The machine will continue rotating counterclockwise as long as the button is held.

If the button is released, the machine will stop, and to resume counterclockwise rotation, hold the button for 5 seconds again.

### 5.6 Operating the machine with the foot pedal

If using the foot pedal, connect the wireless control to it by plugging the cable from the foot pedal into the corresponding port on the side of the control unit. To operate the machine, press the foot pedal, and the machine will cease spinning when the foot is lifted.

During operation, the machine will adhere to the settings configured on the control unit. Therefore, ensure to adjust these settings on the control unit before commencing operation.



## 5.7 Recommended torque and speed

For heavy-duty tasks, it is recommended to operate at a speed of 60-80% using the 'Speed' adjustment. For medium tasks, set the speed to 100%, and for lighter jobs, a speed of 120% is advised.

It is important to consider and follow the tool manufacturer's recommendations in addition to the general guidelines provided above.

Keep in mind that the torque is interconnected with the speed setting, and attempting to operate at maximum torque and speed simultaneously may cause the machine to bind.

## 5.8 Error codes and their meanings

- 0x4310 Motor overtemperature (Fault).
- 0x4285 PU overtemperature warning (Warning).
- 0x7180
- Motor overcurrent
- Motor overspeed
- 0xFF39 Motor overload (No response).
- 0x8311 Torque limit reached (No response).
- 0xFF73 Fatal error (Fault).
- 0xFF74
- Power unit fatal error



## 6. MAINTENANCE

Maintenance must only be performed by a person familiar with this instruction manual. When conducting maintenance, press down the emergency stop on the remote, and unplug the unit from the power grid.

### 6.1 Cleaning

The easiest way to remove grime, such as grease, is to wipe the surfaces with a damp cloth and cleanser. Note that a quickly evaporating film or cleanser does not cause damage to the frame. It is recommended to use a scrubbing cleaning cloth or similar.

DO NOT USE ANY KIND OF SOLVENT SUCH AS THINNER, ACETONE, OR OTHER BASED SUBSTANCES. DAMAGE TO THE PAINT SURFACE MAY OCCUR.

### 6.2 Lubrication

The recommended method is to purchase a new cable from Sacpro AB instead of attempting to lubricate it yourself. However, if you observe the cable becoming dry before a replacement is available, the interim solution is to remove the cable from its housing, immerse it in a bath of hydraulic oil, and then reinsert it into the housing.

### 6.3 Electricity

The person in possession of the machine is responsible for ensuring the proper functioning of all electrical components. In the event of any electrical issues, immediate resolution is imperative. Only individuals with the appropriate authorization and expertise in electricity should undertake the necessary repairs or corrective actions. Prompt attention to electrical matters is essential to maintain the safety and efficiency of the machine.

## 7. INSPECTIONS

Regular machine inspections are crucial for identifying potential issues that could lead to machine breakdowns, personal injuries, or other damages. It is imperative to conduct inspections at the specified intervals mentioned below. This proactive approach significantly enhances the likelihood of detecting and addressing any faults before they escalate, ensuring both the machine's reliability and the safety of individuals involved.

### 7.1 Routine inspection every 20 hours of runtime

Every 20 hours of runtime, you need to perform a more comprehensive inspection. Start by following all the steps mentioned earlier in the 'PRE-OPERATION INSTRUCTIONS.' Additionally, check the following points:

1. Remove the cover from the drive belt powering the spindle and ensure the belt is not damaged, such as being cracked or worn. If any damage is detected, the machine must not be operated until the drive belt is replaced.



## 8. REEL REPLACEMENT

You have the capability to interchange reels, thereby accommodating cables with differing diameters. This feature provides a heightened level of versatility.

1. Begin by releasing the locking mechanism for the reel, located around the back plate.
2. Place the machine with its front side facing upwards.
3. Remove the four nuts securing the front plate and detach the front plate.
4. Disconnect the reel's cable from the spindle of the machine. (You can only disconnect the reel if the spindle rotation allows for a straight upward removal. Ensure the spindle rotation is compatible before attempting to detach the reel.)
5. Lift the reel upwards to remove it.

When assembling the reel, follow the instructions mentioned above in reversed order.

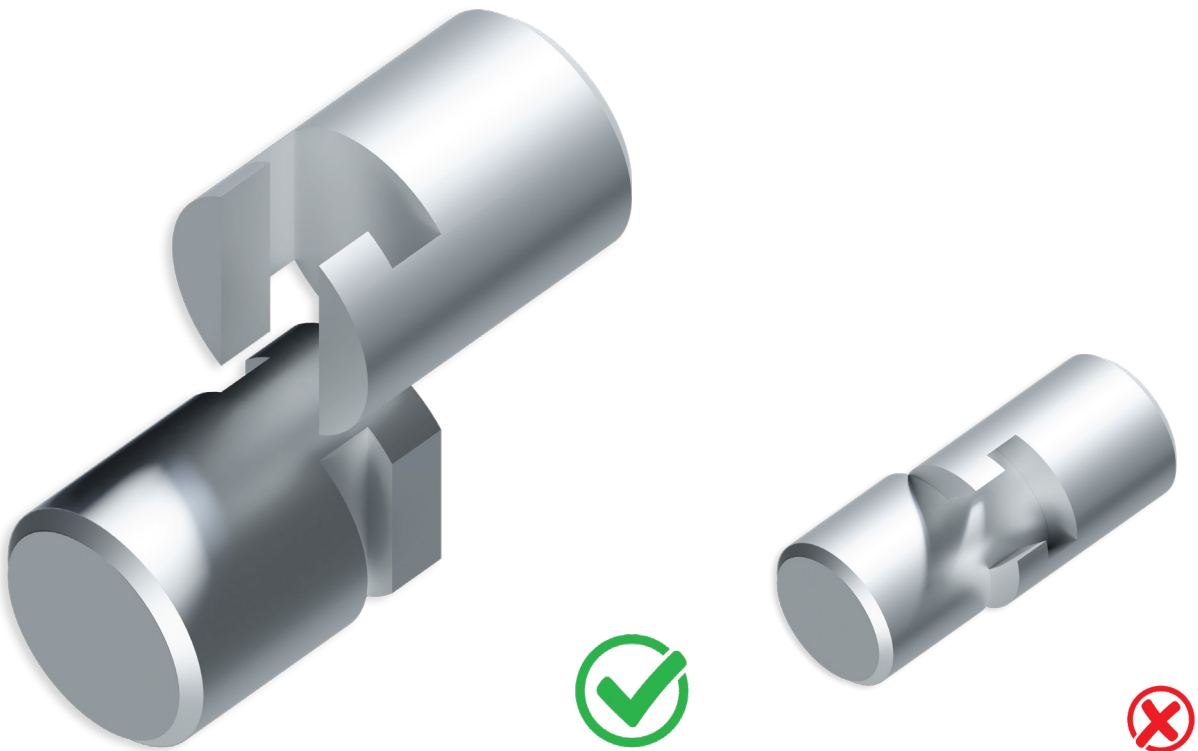

## 9. PARTS LIST

The machine consists of the following parts:

- Main frame
- Electric Motor
- Electric drive unit
- Reel
- Shaft connector
- Adjustable pull handles
- Radio- receiver and transmitter



## 10. ENVIRONMENTAL ASPECT

No emission or waste will be formed when using the machine according to instructions. When the life cycle of the machine comes to an end, all metals need to be sorted and recycled accordingly. Cables can be processed in a center for cable granulation and the control circuit boards can be recycled in a center for electronic waste.

To ensure responsible disposal, follow these recycling guidelines:

- Separate metals from other materials before recycling.
- Remove cables and send them to a designated cable granulation center.
- Prioritize recycling the control circuit boards at an electronic waste recycling center.
- Comply with local regulations and guidelines for proper recycling practices.
- Consult with local recycling facilities for specific instructions on recycling the machine.

***By adhering to these recycling guidelines, you contribute to sustainable waste management. Responsible recycling practices not only reduce the environmental impact but also help conserve valuable resources.***



## DESCRIPTION AND PICTURES HOUSELINER RAPTOR CUTTER



- 1** Adjustment of handle length
- 2** Release handle for wire attachment
- 3** Read before use
- 4** Attachment point for tools
- 5** Locking of wire drum
- 6** Locking / releasing of the front plate
- 7** Rotation lock / release
- 8** Front plate

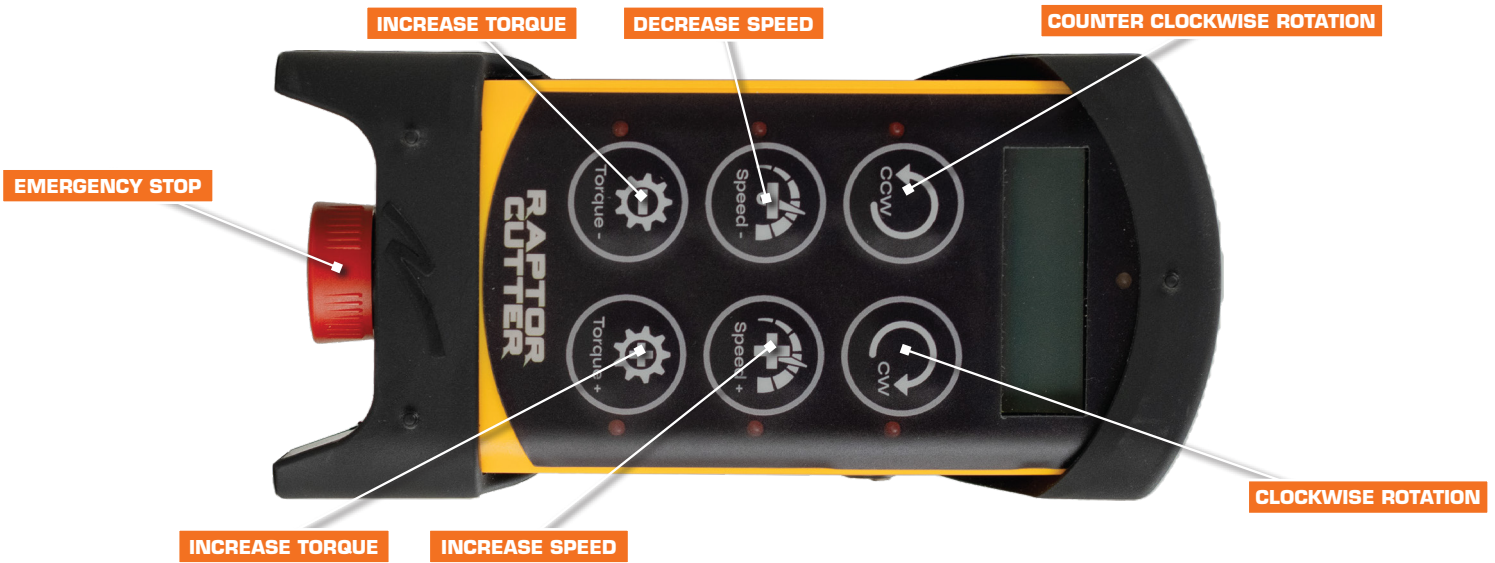

**EN**

## **EU DECLARATION OF CONFORMITY**

1. No: 10021 Raptor Cutter, high speed milling machine.
2. Name and address of the manufacturer or his authorised representative:  
Sacpro AB, Källviksvägen 10, Falun, Sweden.
3. This declaration of conformity is issued under the sole responsibility of the manufacturer: Sacpro AB
4. Object of the declaration (identification of product allowing traceability. It may include a colour image of sufficient clarity to enable the identification of the product, where appropriate).

Electrical milling machine

Brand: Raptor Cutter:

Used for milling of drainpipes cutting epoxy in liners for pipe for branch clearance and insertation in sewer renovations. The machine is intended for professionals use only. Raptor is designed and manufactured for cipp work only. Raptor can only be used with materials and equipment approved by manufacturer and approved for safe usage and for cipp renovation.

5. The object of the declaration described in point 4 is in conformity with the relevant Union harmonisation legislation: 2006/42/EC
6. References to the relevant harmonised standards used, or references to the specifications in relation to which conformity is declared: SFS-EN ISO 12100 and SFS-EN 60204-1
7. Where applicable: the notified body ... (name, number)... performed ... (description of intervention)... and issued the certificate:

8. Additional information:

Signed for and on behalf of: Sacpro AB

***Falun, Sweden - 2023-11-03***

**Fredrik Sterner, CEO**



---

THANKS FOR USING



**HOUSELINER**<sup>®</sup>  
SYSTEM

BY **SACPRO AB**

Källviksvägen 10, SE-791 52 Falun, Sweden  
+46 23 79 06 50 | [info@sacpro.se](mailto:info@sacpro.se)